

ULTRASOUND ASSISTED SUPERCRITICAL FLUID EXTRACTION OF OIL FROM BARU (*Dipteryx alata* Vogel)

Philippe dos Santos¹, Ana C. de Aguiar¹, Juliana Paes¹, Jesuí V. Visentainer², Julian Martínez^{1*}

¹Food Engineering Department, Food Engineering College
University of Campinas (UNICAMP), R. Monteiro Lobato 80
P.O. Box:6121, 13083-862, Campinas, SP, Brazil

² Department of Chemistry
State University of Maringá
Av. Colombo 5790, Jd. Universitário, 87020-900 Maringá, PR, Brazil

E-mail: julian@fea.unicamp.br

Abstract. Brazil has a large number of native forest species and fruits, and some of them proved to be good sources of nutrients, such as baru. The cumbaru or baru (*Dipteryx alata* Vogel) is an important leguminous tree species from the Brazilian Cerrado. The oil extracted from the baru seeds has a high content of oleic and linoleic acid, which is widely used in pharmaceutical and food industries. The objective of this study was to obtain extracts of baru using supercritical fluid extraction with CO₂ (SFE) assisted by ultrasound (US). About 500 g of baru seed were separated from the pulp and grounded. The seed were characterized in terms of proximate composition and fatty acids profile of the extracted oil by the Bligh and Dyer method. The SFE experiments were performed at temperature of 45 ± 3°C, pressure of 20 ± 0.5 MPa and CO₂ flow rate of 0.5 ± 0.1 kg/h. To study the influence of ultrasonic waves in the extraction rate and yield, extractions were performed with and without ultrasound at power of 360 W. The moisture content of the baru seeds was 7.5 %, and the extracted oil showed a predominant presence of unsaturated fatty acids. The yield obtained in first hour of extraction without ultrasound was of 13 % (kg extract /kg sample) while the yield obtained at the same time for the ultrasound at 360 W SFE were near 24 %. The kinetics extraction curve for the US assisted extraction showed a shorter constant extraction rate period (t_{CER}) compared to extraction without ultrasound. The global yield for the SFE experiments with and without ultrasound was 37.45 % and 36.37 %, respectively. These values are similar to total lipids obtained by the Bligh and Dyer method (35 %), which indicates that SFE-CO₂ is effective for the extraction of lipids from baru seeds.

Keywords: Baru, Cumbaru, Yield, Supercritical extraction and Ultrasound.

1. Introduction

The baru nut is a seed of the Baruzeiro plant (*Dipteryx alata* Vog.), a species of shrub belonging to the Leguminosae Faboideae family that is native to the Cerrado. The Cerrado, the second largest biome in South America after the Amazon rainforest, is characterized by a typical hot climate, semi-humid and notably seasonal with rainy summers and dry winters, similar to the savannas. In Brazil the baru nut is known by several popular names such as: barujó, baruzeiro, baruí, coco beans, cumbaru and cumaru. The baru nut is rich in high-quality proteins (23.9 to 29.9%) and in lipids (38.2 to 41.9%) that are predominantly unsaturated fatty acids. Moreover, the baru nut contains high concentration of calcium, iron and zinc [1,2,3].

The extraction of active compounds from raw materials from plant sources is a promising area in the food industry. On the other side, it is a complex task because, in most cases, the target compounds are oxidative or thermolabile substances. Furthermore, severe legal restrictions are proposing the removal of general use of organic solvents in extraction industrial plants. Therefore, there is considerable interest in replacing processes

such as steam distillation and extraction with organic solvents traditionally used for the recovery of these active compounds [4]

The technology of supercritical fluid extraction (SFE) came forward as an alternative to traditional methods for the extraction and fractionation of active compounds. Among the most commonly used supercritical fluid is carbon dioxide (CO₂), whose advantages in extraction processes are: low cost, nontoxicity, no flammability, inert and good extraction capacity [5].

Generally, in a supercritical extraction unit one can observe the effects of temperature, pressure, extraction bed size, solvent flow rate, among others, in order to maximize the yield of a specific compound [6]. The morphology of the particle can also influence the extraction yield of a specific compound, since the extraction occurs also through the path that the solvent must pass inside the solid particle, in order to extract specific compounds [7]. Moreover, the SFE unit capacity has changed by using combined extraction techniques, such as the use of different co-solvents and ultrasonic waves [8].

The ultrasound technique is based on the formation of ultrasonic waves of high frequency, which are capable of causing cavitations due to expansion and contraction cycles undergone by the material. Such cycles disrupt the cell walls of the vegetable matrix, favoring the penetration of the solvent and mass transfer, thus increasing the extract yield [9].

The objective of this investigation was to obtain extracts of baru nut by supercritical fluid extraction (SFE) assisted by ultrasound,

2. Materials and methods

The work was conducted in the Laboratório de Tecnologia Supercrítica, Extração, Fracionamento e Identificação de Extratos Vegetais – DEA/UNICAMP (LASEFI). The raw material was baru seeds (*Dipteryx alata* Vogel) acquired at a local market in Cuiabá, central west Brazil.

2.1 Chemicals

The solvent used in supercritical extractions was CO₂ (Gama Gases, Campinas, SP, Brazil) with 99.0 % purity. For the total phenolics analysis, the Folin-Ciocalteu reagent was purchased from Dinâmica (Dinâmica, SP, Brazil) and gallic acid from Sigma-Aldrich (St. Louis, MO, USA). For chromatography analysis, the fatty acid methyl ester mixture standard 189-19 and tricosanoic acid methyl ester (23:0) were purchased from Sigma (St. Louis, MO, USA). All other solvents and chemicals were of analytical grade.

2.2 Sample preparation

Approximately 0.5 kg of baru seeds (*Dipteryx alata* Vogel) were harvested in the Brazilian Cerrado (region in the state of Mato Grosso), separated from the pulp and ground in a knife mill (Marconi, mod. 340, SP, Brazil) in order to homogenize them and reduce the resistance to mass transfer during the later stages of extraction.

2.3 Sample characterization

Chemical composition. Analyses of moisture and ash were performed according to AOAC techniques [10]. The total lipids were extracted by the Bligh and Dyer [11] method.

Total phenolics. The total phenolics content was determined spectrophotometrically using the Folin-Ciocalteu method, according to the methodology proposed by Singleton, Orthofer and Lamuela-Raventos [12] with modifications. Briefly, 2.5 mL of the diluted Folin-Ciocalteu reagent (1:10 v/v) was added to 0.5 mL of solution of extract in methanol. After 5 min, 2.0 mL of sodium carbonate solution (7.5 %) was added. The absorbance was measured at 760 nm after the mixture remains 2 h in the dark. Gallic acid was used as a standard, and results were expressed as milligrams of gallic acid equivalent (GAE) per gram of extract.

DPPH radical scavenging assay. To determine DPPH radical scavenging assay, the methodology described by Brand-Williams, Cuvelier, and Berset [13] was used. In this procedure, a methanolic solution (initial solution) of 4.0 mg/mL concentration of seed extract was used to prepare serial dilutions. An aliquot of this solution (500 µL) were added to 1500 µL of DPPH (0.024 mg/mL). The absorbance was measured at 517 nm after the mixture remains 2 h in the dark. Gallic acid was used as a standard, and results were expressed as milligrams of gallic acid equivalent (GAE) per gram of extract.

2.4 Soxhlet extraction

The Soxhlet method was selected as conventional extraction technique, using hexane as solvent. In each extraction about 5.0 g of prepared sample were packed in filter paper and inserted in the extractor. Hexane (0.15 L) was added and the system was heated until boiling ($\sim 69\text{ }^{\circ}\text{C}$). The reflux was kept for 6 h, then the solvent was evaporated under vacuum (at $25\text{ }^{\circ}\text{C}$), and the recovered extract was weighed and stored under freezing ($-18\text{ }^{\circ}\text{C}$) for further analyses. The Soxhlet extractions were performed in triplicates.

2.5 Supercritical fluid extraction (SFE)

The kinetic SFE experiments were performed in a supercritical fluid extraction assisted by ultrasound (SFE-US) unit consisting of a 0.295 L extraction column; a pneumatic pump (PP 111-VE MBR, Maximator, Nordhausen, Germany); two thermostatic baths to control CO_2 temperature at the pump inlet and SFE temperature; a flow totalizer and manometers to measure pressure. About 20 g of sample were placed inside the column, whose volume was completed with glass spheres.

The conditions of the SFE experiments were pressure and temperature of $20 \pm 0,5\text{ MPa}$ and $45 \pm 3\text{ }^{\circ}\text{C}$ respectively. The extraction time was 8 hours, defined after preliminary tests and the mass flow rate was fixed at $0.5 \pm 0.1\text{ kg/h}$. The extracts were collected in glass flasks, along the time of extraction, and weighed in analytical balance. The solvent used was CO_2 (Gama Gases, Campinas-SP, Brazil) with 99.0 % purity. Figure 2 illustrates the SFE+US unit used in the experiments.

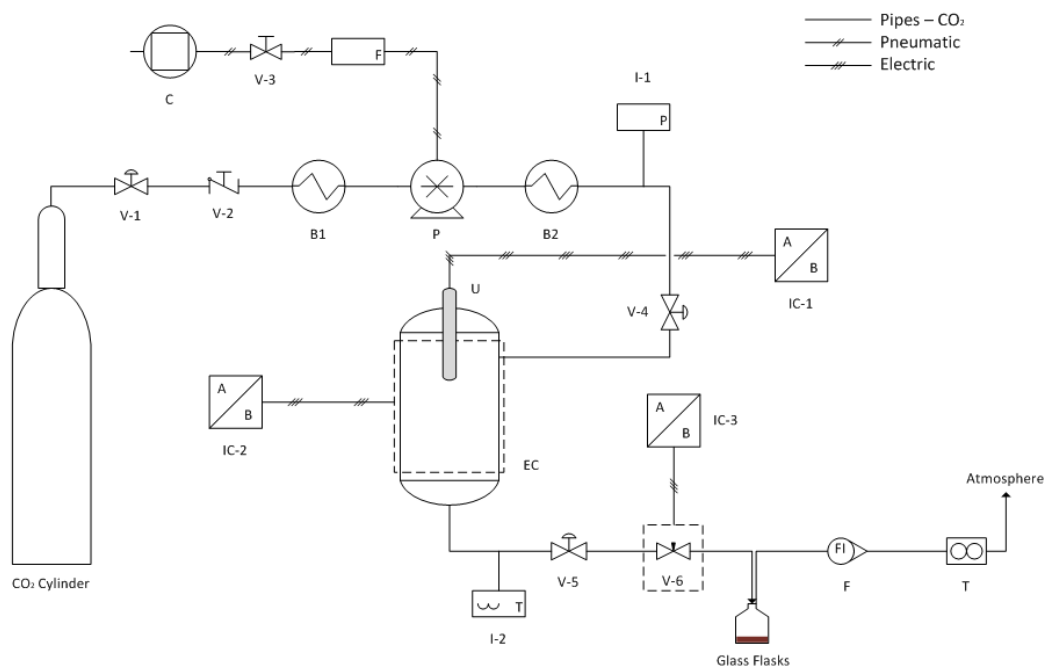

Figure 1. Diagram of supercritical extraction unit with carbon dioxide assisted by ultrasound; V-1, V-2, V-3, V-4, V-5 e V-6 – Control valves; V-6 – Micrometer valve; C- Compressor; F - Compressed air filter; B1 – Cooling bath; P - Pump; B2 – Heating bath; I-1 e I-2 – Pressure and temperature indicators, respectively; IC-1, IC-2 e IC-3 – Indicators and controllers of ultrasound power, temperature of extraction column and temperature of micrometer valve, respectively; EC – Extraction column ;U – Ultrasound probe; F – Rotameter; T –Flow meter.

The ultrasonic system (Unique Group, model DES500) is composed of a transducer unit with frequency of 20 kHz and a 800 W variable output power controller. The ultrasound probe was installed inside of the SFE column. The ultrasound waves (360 Watts) were applied during the 8 hours of extraction.

2.6 Overall extraction curve adjustment

The extraction curves were fitted to a spline of two or three lines using PROREG procedure of SAS System 8.02, followed by the procedure NLIN the same program. This methodology was described by Rodrigues et al. [14] and Meireles [15]. The equation involved in the adjustments is shown below. This setting determines the length of periods CER (constant extraction rate), FER (falling extraction rate) and DC (diffusion controlled), beyond values of mass transfer rate and concentration of extract in the solvent at the extractor outlet during the CER period.

$$m_{ext} = (b_0 - C_1 b_2) + (b_1 + b_2)t \quad (1)$$

where: b_0 , b_1 and b_2 are model parameters; C_1 is intersection first with second line; m_{ext} is extract mass (yield) and t is time.

2.7 Extract evaluation

The fatty acids of the extracted lipids (Bligh and Dyer, Soxhlet, SFE and SFE+US) were converted into fatty acids methyl esters by the method of Hartman and Lago [16], as modified by Maia and Rodrigues-Amaya [17]. Methyl esters were separated by gas chromatography in a Varian equipment, model 3380, equipped with flame ionization and cyanopropyl capillary column (100 m × 0.25 i.d., 0.25 μm film thickness, CP-7420 Varian, EUA). The gas flow rates used were 1.0 mL/min carrier gas (H₂), 30 mL/min make-up gas (N₂) and 300 mL/min flame gases (H₂ and synthetic air, respectively). The sample splitting rate was 1:100 and the samples (2 μL) were injected in triplicate. The operation parameters were as follows: detector temperature 240 °C, injection port temperature 220 °C, column temperature 165 °C for 18 min, programmed to increase at 4 °C/min to 235 °C and kept at this temperature for 14.5 min. The peak areas were determined by Workstation 5.0 (Varian) acquisition program. For the fatty acid identification, retention times were compared with those of standard methyl esters (fatty acid methyl ester mixture standard 189-19).

3. Results and discussion

3.1 Sample characterization

According to the data shown in Table 1, one can observe that the baru seeds present considerable amounts of lipids (32 %), and as a result, are good source of energy. The measured moisture content (7.4 %) is in agreement with the literature, ranging from 2.93 to 10.7 % [18, 19]. The lipid content is high, totaling 32 % of the weight of baru seeds. The ethereal extract obtained by Vera [18] varied from 31.16 to 35.87 %. In plants, variations in chemical composition between plants of the same species can be explained by differences in climate, soil, agricultural practices and genetic characteristics of the seeds analyzed.

Table 1. Proximate composition (% w/w) of baru seeds.

Parameter	Result
Moisture	7.4 ± 0.4
Ash	10.1 ± 0.2
Total lipids	32 ± 1

Results are mean±standard deviation of experiments performed in triplicate.

The yield obtained by Soxhlet technique with solvent hexane (37 %) was approximately 15 % higher than that obtained with the technique of cold extraction: the Bligh and Dyer method. This difference can be explained by the different extraction conditions for each of the methods employed, the solvent hexane solubilized greater amount of solute compared to chloroform, besides the possibility of solubilizing different compounds due to their polarity.

The total phenolic content of methanolic extracts of baru seeds was 43.4±0.8 mg GAE/g extract (792.74 mg GAE/ 100g fresh weight). In comparison with other vegetable material, this result shows that the baru seeds might be considered as a source of total phenolics. In fact, it presented a higher phenolic content compared with other fruits, such as tomato (30 mg/100 g of fresh weigh) and apples (48 mg/100g of fresh weight [20]). The DPPH radical scavenging assay result was 39.6±0.4 mg GAE/g extract.

Table 2 presents the fatty acid profile of the extracted oil from baru seeds by Bligh and Dyer [11] and Soxhlet methods.

Table 2. Fatty acids (relative percentage) profile of Bligh and Dyer and Soxhlet extracts of baru seeds.

Fatty acids	Bligh and Dyer	Soxhlet
16:0	7.32±0.13	7.16±0.02
18:0	4.77±0.03	4.81±0.04
17:1	0.29±0.05	0.29±0.04
18:1 n-9	50.2±0.36	51.1±0.15
18:1n-7	0.47±0.02	0.47±0.02
17:0	0.25±0.03	0.33±0.08
18:2n-6	26.1±0.68	25.6±0.17
18:3n-3	0.13±0.01	0.14±0.01
20:0	1.23±0.03	1.24±0.03
22:0	2.33±0.06	2.42±0.04
24:0	4.47±0.27	4.74±0.03
20:1	0.27±0.00	0.28±0.00
20:2	2.10±0.20	1.34±0.03
SFA	20.37±0.25	20.70±0.04
MUFA	51.31±0.51	52.22±0.09
PUFA	28.33±0.70	27.08±0.13

SFA: saturated fatty acids, MUFA: monounsaturated fatty acids and PUFA: polyunsaturated fatty acids.

The major fatty acids of baru seeds are 18:1n-9 (oleic acid), reaching more than 50 % of the fatty acid profile, followed by 18:2n-6 (linoleic acid). This result evidences the predominance of polyunsaturated fatty acids in their lipid fraction. Further in accordance with Table 2, the sum of monounsaturated fatty acids had the highest concentration (MUFA: 51.31 %), followed by polyunsaturated (PUFA: 28.33 %) and the saturated (SFA: 20.37 %). This profile is interesting with regard to human nutrition since the acid 18:2 n-6 is an essential fatty acid, which is involved in several metabolic processes [21]. Linolenic acid (18:3n-3) was also identified in the baru seeds, however, in very low concentrations (0.13 %). The fatty acid profile in the oil extracted by Soxhlet technique is very similar to that obtained by Bligh and Dyer [11] method, suggesting that the process of extraction with hexane depletion did not cause the degradation of polyunsaturated fatty acids or alter the composition of the oil obtained.

3.2 Supercritical CO₂ experiments

Table 3 shows the values of the parameters obtained for the supercritical extraction of baru seeds. It is observed that the extraction bed was maintained constant for extraction with and without ultrasound.

Table 3. Parameters of supercritical extraction assisted by ultrasound

Parameters	Conditions
T (°C)	45±3
P (MPa)	20±0.3
ρ (kg/m ³)	812.69
Q _{CO₂} (kg/h)	0.5±0.1
F (kg)	0.0204±0.0003

T - temperature; P - pressure; ρ - solvent density; Q_{CO₂} - solvent mass flow rate; F - mass of raw material into the extraction bed

The curves shown in Figure 2 demonstrate the behavior of supercritical extraction kinetics. The process begins with a period with constant extraction rate (CER), and this stage is characterized by the extraction of compounds readily available to the solvent. When the solute of easy access begins to exhaust, intraparticle diffusion becomes the principal mechanism of mass transfer in SFE. Thus, the extraction curves assume a typical format of a diffusion curve, with reduced extraction rate until the global yield (X₀) is reached.

The influence of ultrasound in the constant extraction rate period can be observed in Figure 2. This influence is also reflected in the values of the constant extraction rate time (t_{cer}), shown on Table 4. The yield obtained in the first hour of extraction without ultrasound was of 13 % (kg extract /kg sample) while the yield obtained at the same time for the ultrasound at 360 W SFE was near 24 %. During the periods of decreasing extraction rate and of diffusion, the application of ultrasonic waves increased the yield, and at the end of the

extraction the global yields were approximately 35.8% without ultrasound and 36.7% with ultrasound. This behavior is explained due to cavitation near the wall of the cell matrix which causes a disturbance in the vegetable matrix, thereby releasing the intraparticle material and increasing the extraction velocity. Table 4 shows the adjusted kinetic parameters of SFE from baru at 20 MPa and 40 °C with (360W) and without ultrasound.

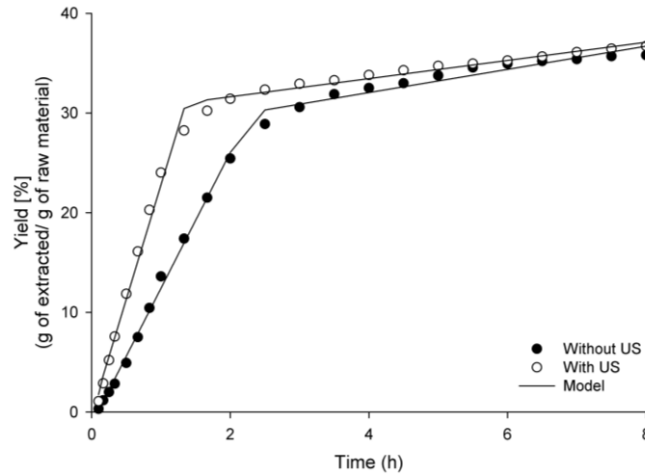

Figure 2. Modeled and experimental extraction curves from baru seeds at 20 MPa and 45 °C without and with ultrasound at 360W.

Table 4. Adjusted kinetics parameters with Equation 1 applied to supercritical CO₂ extraction from baru seeds at 20 MPa and 40 °C with and without ultrasound.

Process Parameters	With Ultrasound	Without Ultrasound
t_{CER} (min)	81,5606	137,7
m_{CER} (kg/s)	0,00126	0,00123
Y_{CER} (% , d.b.)	31,05	30,07

where: m_{CER} (kg/s) - mass transfer rate during constant extraction rate period. Y_{CER} (% , d.b.) – yield in constant extraction rate period.

Figure 3 and 4 presents fatty acids (SFA, MUFA and PUFA) extraction yield of SFE without and with ultrasound, respectively.

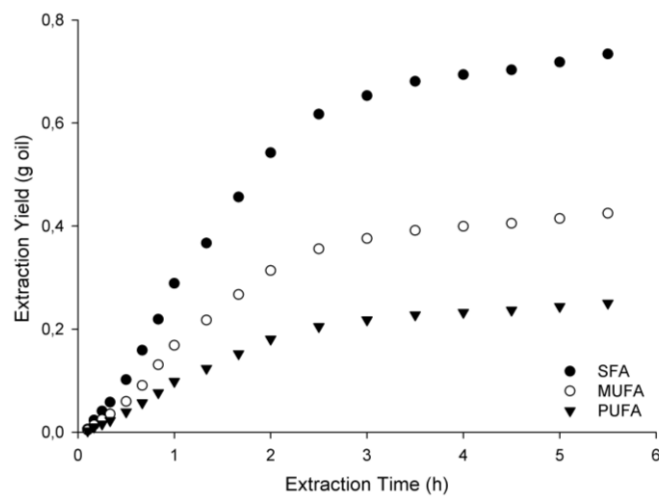

Figure 3. Fatty acids (SFA, MUFA and PUFA) extraction yield of SFE without ultrasound.

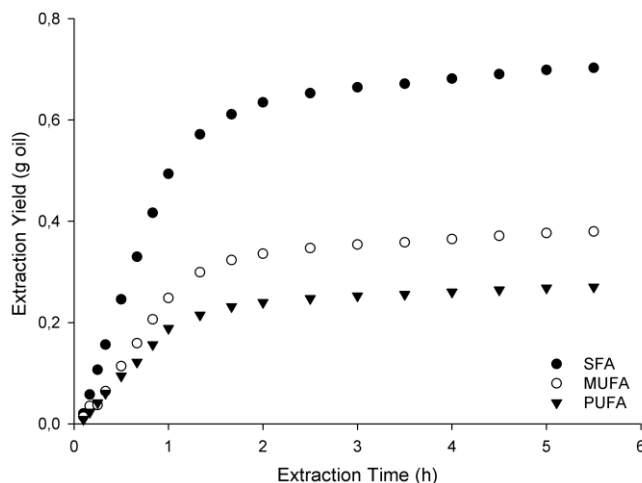

Figure 4. Fatty acids (SFA, MUFA and PUFA) extraction yield of SFE assisted by ultrasound.

According to Figures 3 and 4, it can be observed that the kinetics extraction of different groups of fatty acids (SFA, MUFA and PUFA) found in the baru seeds was influenced by the presence of ultrasound in the extraction process and has similar behavior to that observed in the oil extraction kinetics (Figure 3). In general, a higher extraction rate was found for all groups of fatty acids when the extraction process was assisted by ultrasound. Thus, the presence of ultrasound favors the transfer of triglycerides and other lipid compounds from the solid matrix to the supercritical solvent.

4. Conclusions

The major fatty acids of baru seeds are 18:1n-9 (oleic acid), reaching more than 50 % of the fatty acid profile. Supercritical CO₂ extraction assisted by ultrasound increased global yield of baru seeds extract compared to SFE. The yield obtained in first hour of extraction without ultrasound was of 13 % (kg extract /kg sample) while the yield obtained at the same time for the SFE with ultrasound at 360 W was near 24 %. The model proved to be effective to describe the kinetics of supercritical extraction assisted by ultrasound, and presence of ultrasound favors the transfer of triglycerides and other lipid compounds from the solid matrix to the supercritical solvent.

Acknowledgments

The authors wish to thank FAEPEX, CNPq and FAPESP (Project 2011/08656-7) for the financial support.

References

- [1] E. M. D. A. Siqueira, A. M. F. Marin, M. S. B. Cunha, A. M. Fustinoni, L. P. Sant'Ana, S. F. Arruda, Consumption of baru seeds [*Dipteryx alata* Vog.], a Brazilian savanna nut, prevents iron-induced oxidative stress in rats, *Food Research International* 45 (2012) 427-433.
- [2] A. G. O. Sousa, D. C. Fernandes, A. M. Alves, J. B. Freitas, M. M. V. Naves. Nutritional quality and protein value of exotic almonds and nut from the Brazilian Savanna compared to peanut, *Food Research International* 44 (2011) 2319-2325.
- [3] M. A. Marin, S. F. Arruda, E. M. A. Siqueira, Minerals, phytic acid and tannin contents of 18 fruits from the Brazilian savanna, *International Journal of Food Science* 60 (2009) 180-190.
- [4] Martinez, J. L. *Supercritical fluid extraction of nutraceuticals and bioactive compounds*. Boca Raton, FL: CRC Press, 2008.
- [5] G. Brunner, *Gas extraction: an introduction to fundamentals of supercritical fluids and the application to separation processes*. Darmstadt; New York: Steinkopff; Springer, 1994.
- [6] A. Perva-Uzunalić, M. Skerget, B. Weinreich, Z. Knez, Extraction of chilli pepper (var. *Byedige*) with supercritical CO₂: Effect of pressure and temperature on capsaicinoid and colour extraction efficiency. *Food Chemistry*, 87

- (2004) 51-58, 2004.
- [7] M. D. Esclapez, J. V. García-Pérez, A. Mulet, J. A., Cárcel. Ultrasound-Assisted Extraction of Natural Products. *Food Engineering Reviews*, 3 (2011) 108-120.
 - [8] Y. Gao, B. Nagy, X. Liu, B. Simándi, Q. Wang. Supercritical CO₂ extraction of lutein esters from marigold (*Tagetes erecta* L.) enhanced by ultrasound. *Journal of Supercritical Fluids*, 49 (2009) 345–350.
 - [9] M. Toma, M. Vinatoru, L. Paniwnyk, T. J. Mason. Investigation of the effects of ultrasound on vegetal tissues during solvent extraction, *Ultrasonics Sonochemistry*, 8 (2001) 137-142.
 - [10] AOAC, Association of Official Analytical Chemists, *Official Methods of Analysis*, (16th ed.) AOAC, Arlington, VA, 1995)
 - [11] E. G. Bligh and W. J. Dyer. A rapid method of total lipid extraction and purification. *Canadian J. Biochemistry and Physiology*, 37 (1959) 911–917.
 - [12] V. L. Singleton, R. Orthofer, R. M. Lamuela-Raventos. Analysis of Total Phenols and Others Oxidation Substrates and Antioxidants by Means of Folin-Ciocalteu Reagent. *Methods in Enzymology*, 299, (1999) 152.
 - [13] W. Brand-Williams, M.E. Cuvelier and C. Berset. Use of a free radical method to evaluate antioxidant activity. *Lebensmittel – Wissenschaft Technologie*, 28 (1995) 25-30.
 - [14] V. M. Rodrigues, E. M. B. D. Sousa, A. R. Monteiro, O. Chivovone-Filho, M. O. M. Marques, M. A. A. Meireles. Determination of the solubility of extracts from vegetable raw material in pressurized CO₂: a pseudo-ternary mixture formed by cellulosic structure + solute + solvent. *Journal of Supercritical Fluids*, 22 (2002) 21-36.
 - [15] Meireles, M. A. A. Extraction of Bioactive Compounds from Latin American Plants. In: J. Martinez (Org.). *Supercritical fluid extraction of nutraceuticals and bioactive compounds*. Boca Raton: CRC Press – Taylor & Francis Group, 2008, p. 243-274.
 - [16] L. Hartman and R. C. A. Lago. A rapid preparation of fatty acid methyl esters from lipids. *Laboratory Practice*, 22 (1973) 475–476.
 - [17] E. L. Maia. and D. Rodrigues-Amaya. Avaliação de um método simples e econômico para metilação de ácidos graxos com lipídios de diversas espécies de peixes, *Revista do Instituto Adolfo Lutz*, 53 (1993) 27–35.
 - [18] R. Vera, M. S. S. Junior, R. V. Naves, E. R. B. Souza, E. P. Fernandes, M. Caliani, W. M. Leandro. Características químicas de amêndoas de barueiros (*Dipteryx alata* Vog.) de ocorrência natural no cerrado do estado de Goiás, Brasil. *Revista Brasileira de Fruticultura*, 31 (2009), 112-118.
 - [19] T. S. Melhem. Fisiologia do desenvolvimento de *Dipteryx alata* Vog.: contribuição ao seu estudo Thesis (Doctorate) – Instituto de Biociências da Universidade de São Paulo, São Paulo, 1972.
 - [20] A. Mansouri, G. Embrarek, E. Kokalou, P. Kefalas. Phenolic profile and antioxidant activity of the Algerian ripe date palm fruit (*Phoenix dactylifera*), *Food Chemistry*, 89 (2005) 411-420.
 - [21] D. J. Jenkins, C. W. Kendall, A. Marchie, T. L. Parker, P. W. Connelly, W. Qian. Dose response of almonds on coronary heart disease risk factors: blood lipids, oxidized low-density lipoproteins, lipoprotein(a), homocysteine, and pulmonary nitric oxide. A randomized, controlled, crossover trial. *Circulation*. 106(11) (2002) 1327-32.